



ST-2001

DC VOLTMETER



INSTRUCTION MANUAL

INDEX	PAGE
1.INTRODUCTION.....	1
2.SAFETY NOTES.....	2
3.FEATURES.....	3
4.SPECIFICATIONS.....	4
5.GENERAL.....	5
6.INSTRUMENT LAYOUT.....	6-8
7.MEASUREMENT.....	9
8.MAINTENANCE.....	10

1. INTRODUCTION

NOTE

This meter has been designed and tested According to CE Safety Requirements for Electronic Measuring Apparatus, IEC/ EN 61010-1 and other safety standards. Follow all warnings to ensure safe operation.

WARNING

READ "SAFETY NOTES" (NEXT PAGE) BEFORE USING THE METER.

2. SAFETY NOTES

- Read the following safety information carefully
Before attempting to operate or service the meter.
- Use the meter only as specified in this manual.
Otherwise, the protection provided by the meter
may be impaired.
- Rated environmental conditions :
 - (1) Indoor Use.
 - (2) Installation Category III.
 - (3) Pollution Degree 2.
 - (4) Altitude up to 2000 meters.
 - (5) Relative humidity 80% max.
 - (6) Ambient temperature 0~40°C.
- Observe the International Electrical Symbols
listed below :



Meter is protected throughout by double insulation or reinforced insulation.



Warning ! Risk of electric shock.



Caution ! Refer to this manual before using the meter.

DC Direct current.

3.FEATURES

- Big-size Liquid Crystal Display (112x59mm)
- Back light function.
- Analog scale with Bar-graph for viewing. (100 bars)
- 10000-count LCD (high resolution)
- DCV Ranges: 99.99mV~999.9V
- 5 manual ranges controlled by rotary switch
- Data Hold function
- Low battery indication
- 9V power supply
- Best resolution of 0.01mV (10uV)
- Comply with CE standard EN61010-1.
- Water proof design, protection class: IP54
- Precision meter for factory maintenance, field servicing and educational purposes.
- Easy to carry handle that doubles as a convenient stand.

4.SPECIFICATIONS(All at 23°C±5°C, ≤ 80%R.H)

DC Voltages :

Range	Resolution	Accuracy
100.00mV	10uV	±(0.1%rdg+4dgt)
1000.0mV	100uV	±(0.1%rdg+4dgt)
10.000V	1mV	±(0.1%rdg+4dgt)
100.00V	10mV	±(0.1%rdg+4dgt)
1000.0V	100mV	±(0.1%rdg+4dgt)

5. GENERAL

- **Operating Temperature & Humidity :**
0°C~40°C, 80% Max. R.H.
- **Storage Temperature & Humidity :**
-10°C~50°C, 80% Max. R.H.
- **Power source :**
1.5V (AA) battery x 6.
- **Dimensions :**
Approx. 177mm(L) x 200mm(W) x 105mm(D)
with holster
- **Weight :**
Approx. 1210g (batteries and holster included)
- **Safety Standards :**
EN 61010-1 CAT II 1000V / CAT III 600V
EN 61326-1
- **Low Battery Indication :**
"B" sign appears on the display when the battery
voltage drops below accurate operating level.
- **Accessories :**
Instruction Manual
Batteries
Test leads AL-11-5 (Optional)
Alligator (Optional)
Holster (Optional)

6. INSTRUMENT LAYOUT

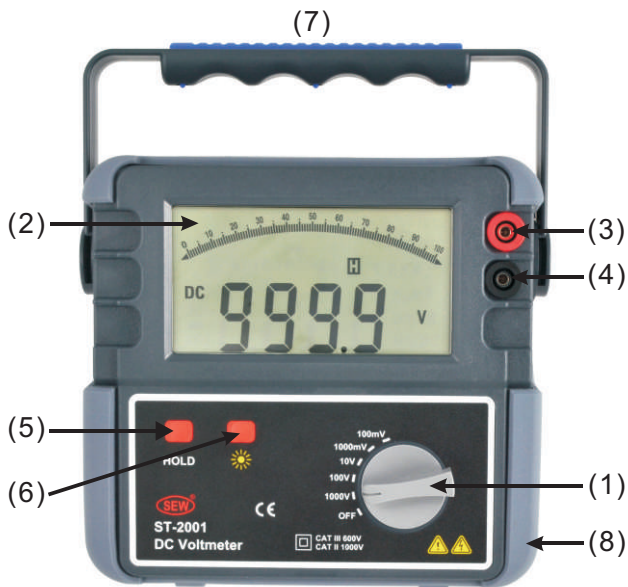

(1) Rotary Switch

(5) HOLD Button

(2) Big-size LCD

(6) Back light Button

(3) Positive terminal (+)

(7) Handle

(4) Negative terminal

(8) Holster

(COM)

(1) Rotary switch

The rotary switch selects the range for different voltages.

(2) Big-size LCD (112x59mm)

10000-count LCD.

Analog scale with Bar-graph for viewing(100 bars).

(3) Positive terminal (+)

This is the positive terminal for DC voltage measurement. Use the red test lead to connect.

(4) Negative terminal (COM)

This is the negative terminal for DC voltage measurement. Use the black test lead to connect.

(5) HOLD Button

Pressing the HOLD button (HOLD annunciator turns on) makes the meter stop updating the LCD display. HOLD function can be cancelled by changing the range or pushing the HOLD button again.

(6) Back light Button

Press the "☀" button to enable the back light function. The backlight function will last for about 8 seconds. Or you can press the "☀" button again to disable the function.

(7) Handle

Easy-to-carry handle that doubles as a convenient stand.

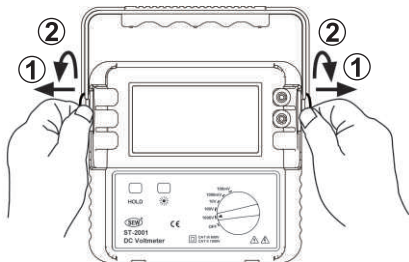

① Pull to rotate

② Rotate the handle with different angles

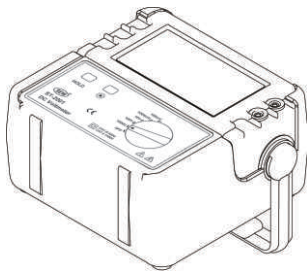

The handle functions as a stand

(8) Holster

Rugged holster for protection.

7. MEASUREMENT

Before proceeding with measurement, read the safety notes.

DC Voltage measurement

- (1) Insert the Red test lead to the positive terminal (+) and insert the black test lead to the negative terminal (COM).
- (2) Select the appropriate range for DCV measurement. If the magnitude of the voltage is unknown, select the highest range first (1000V). Then reduce the range until the desired resolution is reached.
- (3) Get the reading from the big-size LCD directly.

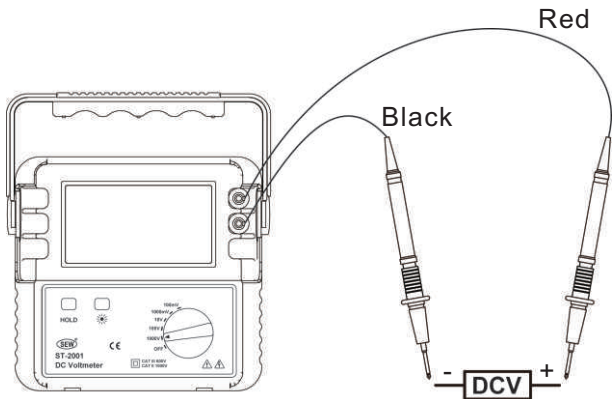

8. MAINTENANCE

Battery replacement :

When the low battery warning symbol appears, replace with new batteries as follows :

- (1) Disconnect the test leads from the instrument and turn off the power.
- (2) Unscrew the battery cover and replace with new batteries.
- (3) Close the battery cover and screw.

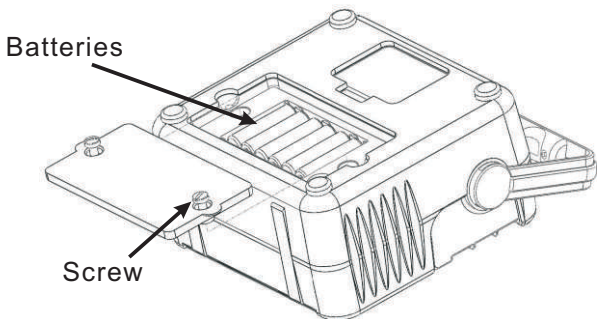

Cleaning and Storage :

WARNING

To avoid electrical shock or damage to the meter, do not get water inside the case.

Periodically wipe the case with a damp cloth and detergent. Do not use abrasives or solvents. If the meter is not used for over 60 days, remove the batteries for storage.

Due to our policy of constant improvement and development, we reserve the right to change specifications without notice.

CAT IV - Is for measurements performed at the source of the low voltage installation.

CAT III - Is for measurements performed in the building installation.

CAT II - Is for measurement performed on circuits directly connected to the low voltage installation.

CAT I - Is for measurements performed on circuits not directly Connected to Mains.