



# Model HST-90U

## Analog Panel Meters



HST-90U 3.5"

### Features

- **DC Ranges:** Microammeter, Milliammeter, Ammeter, Millivoltmeter, Voltmeter.
- **AC Ranges:** Milliammeter, Ammeter, Voltmeter, Frequency Meter.

■ Consult Hoyt for measuring ranges and scales

### Specification

- Accuracy: AC class 2.5.  
DC class 2.0.  
Rectifier class 2.0.

#### Hz Meter

Measuring Ranges: 45~56 Hz, 45~55 Hz, 55~65 Hz.  
Rated Voltage: 110V, 220V.  
Accuracy: Class 2.0.

- Case & Composition: Polycarbonate front and Polybutylene Terephthalate (PBT).
- Color: Black case and white scale plate.
- Pointer: Sword type color in black.
- Mounting: Three studs mounting.

#### General

Operating Temperature: 32°F to 104°F (0°C to 40°C).  
Storage Temperature: -4°F to 131°F (-20°C to 55°C).  
Relative Humidity: 20% to 80%RH (Nominal Use).



### Dimensions

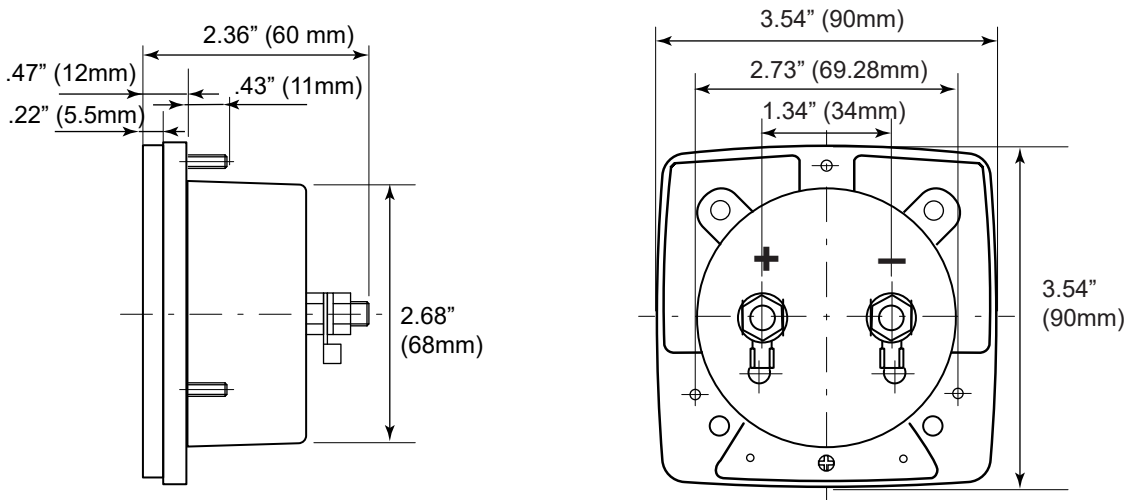

### PANEL CUT-OUT

