



BZCT050, 070, 120, 160 & 210

Circular Toroid (Zero Current Transformer)



Features

- For use in conjunction with Broyce “Type A” Earth Leakage Relays.
- Designed to detect leakage current and transmit a proportional signal to an Earth Leakage Relay.
- Surface mounting with 4 fixing slots (BZCT160 and 210 supplied with separate mounting feet).
- Slim design.

Technical Specification

Size availability* and part number:	50mm (BZCT050) 70mm (BZCT070) 120mm (BZCT120) 160mm (BZCT160) 210mm (BZCT210)
* internal diameter	

Rated system voltage: 720VAC

Insulation level: 3kVAC

Current ratio: 1/1000

Rated operational current (I.e.):	BZCT050 – 85A (50mm ²) BZCT070 – 160A (95mm ²) BZCT120 – 250A (240mm ²) BZCT160 – 320A (400mm ²) BZCT210 – 400A (500mm ²)
-----------------------------------	---

Max. cross-section/phase cable size shown in brackets and assumes 3P + N copper cables.

Maximum permissible current: 1kA cont., 5kA for 1.5s, 100kA for 0.05s

Minimum I Δ n setting on Earth Leakage Relay for each type of toroid: 0.03A

Max. Distance 50m (max.) Between toroid and ELR

Ambient temperature: -20 to +60°C

Relative humidity: +95%

Housing: Grey ABS

Mounting option: Surface mount only using fixing slots provided.

Terminal conductor size: $\leq 2.5\text{mm}^2$ solid / $\leq 1.5\text{mm}^2$ stranded

Approvals: CE Compliant.
Conforms to: IEC61869 parts 1 and 2

Function Diagram

Typical connection examples are shown below.

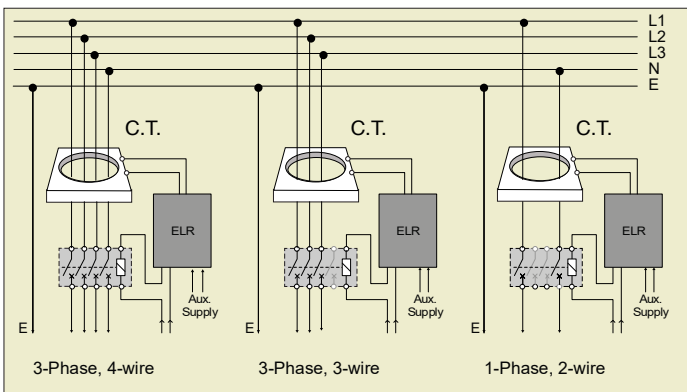

Installation Note

- Installation work must be carried out by qualified personnel.
- Before installation, isolate the supply to the cables that are to be passed through the toroid.
- Installation of the toroid, along with the Earth Leakage Relay must be carried out in accordance with the latest wiring practices and regulations.



BZCT050, 070, 120, 160 & 210

Circular Toroid (Zero Current Transformer)

Installation DO's and DONT's

Correct installation of the Earth Leakage Relay and toroid should ensure trouble free operation, in particular, if this document is followed.

1. Always ensure the Earth conductor DOES NOT pass through the toroid. If this is unavoidable, the Earth must be routed back through the toroid again and around, as shown in Fig.1.
2. DO NOT pass individual conductors through separate toroids, as shown in Fig. 3.
3. Ensure the cable is central in the toroid (see Fig. 4)
4. As a rule, select a toroid that has an inside diameter which is twice that or greater than the outsider diameter of the cable(s) to be passed through (see Fig. 5)
5. Place the toroid on a straight section of cable, not near a bend (see Fig. 6)
6. Keep the cable and toroid away from intense magnetic fields from nearby equipment.

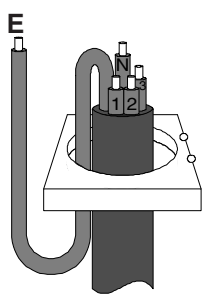

Fig. 1

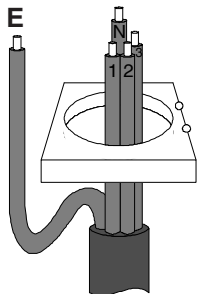

Fig. 2

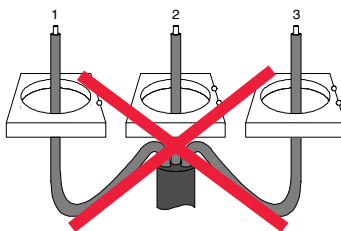

Fig. 3

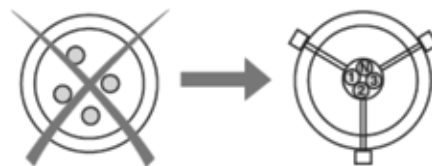

Fig. 4

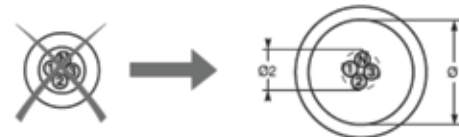

Fig. 5 $\phi 1 \geq \phi 2$

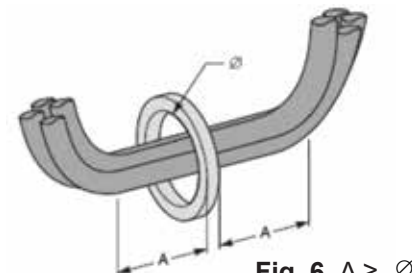

Fig. 6 $A \geq \phi$

Dimensions (in mm)

Toroid Type:	A Dia.	B	C	D	E	F	Weight
BZCT050	50	63	98	40	20	42	88g
BZCT070	70	105	117	40	20	53	135g
BZCT120	120	155	170	40	20	80	265g
BZCT160	160	150	253	60 [^]	33	120	1075g
BZCT210	210	149	304	60 [^]	33	145	1300g

[^]exc. mounting feet

