



Model 1824 LP

Digital Loop / PSC / Earth Tester



CE

Features

- Microprocessor-controlled.
- Measures Earth Resistance without the need for poles in the ground or external measuring wires.
- Earth measurement uses the real earth current path and the current generated by the electric network, without the need for any disconnection.
- The Earth Resistance displayed is exactly the earth resistance that the earth current will need to go through if an earth fault occurs. (you do not need to add all the bonding points and connection paths)
- Displays voltage supply at the transformer (Line to Neutral), without loading the transformer.
- Single one smart push button operation; ON, Scroll through results and menus.
- Checks wiring integrity (LEDs).
- Auto-off / Auto-ranging (software range).
- Color-coded test leads.
- Combined prospective short circuit current, loop, and earth tester.
- Loop test for L-E and PSC between L-N.
- Voltage test L-N.
- Display can be customized for large orders.

Specifications

Loop impedance range L-E	0.03-2000Ω (software ctrl)
Test currents in each loop	11.76A at 230V / 50Hz
Voltage measurement	50 to 280V AC (Sine)
Earth wire/path return resistance	0.01-2000Ω (software ctrl)
Neutral wire resistance	(Not available, see 1826 NA)
Line wire resistance & transformer windings	(Not available, see 1826 NA)
PSC current (L-N) max	6kA at 230Vac supply
PSC current (L-E) max	(Not available, see 1826 NA)
Operating voltage	230V±20V at 50Hz Sine
Typical Accuracy	
Loop impedance	±4%rdg ± 2dgt
PSC current	±10%rdg ± 5dgt
Voltage	±2%rdg ± 1dgt
Operating - temperature	-10°C to +40°C
- humidity	80% Max. relative humidity
Dimensions	170(L) x 165(W) x 92(D)mm
Weight (battery included)	Approx. 970g
Power source	1.5V (AA) x 8
Safety standard	EN 61010-1 CAT III 300V EN 61326-1

Accessories

- Instruction manual
- Test leads
- Shoulder belt
- Batteries

The 1824 LP is a new generation of instruments for the testing of electrical installations.

It has a **built-in Earth tester** which does not require the use of poles or long wires. This instrument is useful for fault-finding or commissioning of electrical installations.

This new instrument uses a three-wire unique principle of operation. It displays the main system voltage of the power utility, without loading the wiring.

The 1824 LP displays the Loop Impedance between Line and Earth ($Z_L + Z_E = Z_{L-E}$) and Prospective Short Circuit between Line and Neutral.

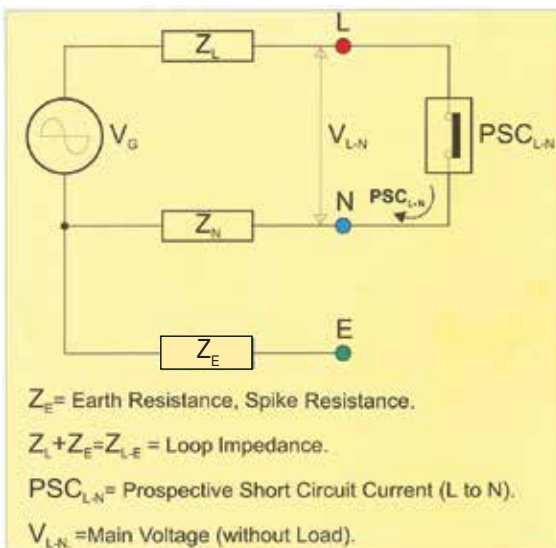

Hoyt Electrical Instrument Works, Inc.

23 Meter Street
Penacook, NH 03303

Phone: (800) 258-3652
Fax: (603) 753-9592
Email: sales@hoytmeter.com

www.hoytmeter.com