

# **277HP Non-contact High Voltage Detector**

---



**INSTRUCTION MANUAL**

Index	Page
1. Introduction.....	1
2. Safety precaution.....	2
3. Applications.....	3
4. Features & specifications.....	3
5. Instrument layout.....	5
6. Operation.....	6
7. Maintenance.....	10

# 1. Introduction

## NOTE

This detector has been designed and tested according to CE Safety Requirements for Electronic Measuring Apparatus. Follow all warnings to ensure safe operation.



**WARNING**

**READ "SAFETY PRECAUTION" (NEXT PAGE)  
BEFORE USING THE HIGH VOLTAGE DETECTOR**

## **2. Safety precaution**

Electricity can cause severe injuries with high voltages. Therefore it is very important to read the following info before using the Non-contact High Voltage Detector.

This must only be used and operated by a competent trained person and in strict accordance with the instructions. We will not accept liability for any damage or injury caused by misuse or non compliance with instructions and safety procedures.

Examine the Non-contact High Voltage Detector to make sure it is clean and dry. If it is not, wipe with a clean, dry, lint-free cloth.

The high voltage detector test should always be used as an indication only.

Read all safety information carefully before attempting to operate or service the High Voltage Detector.

Use the High Voltage Detector only as specified in this manual. Otherwise, the protection provided by the High Voltage Detector may be impaired.

Please keep in your mind to wear high insulated gloves when you test high voltages between 600V~1.5kV.

Please keep in your mind to wear high insulated gloves and to use the hot stick HS-120 or HS-175 when you test high voltages between 1.5kV~132kV

### **3. Applications**

- Non-contact detection of live voltages
- Find faults in cables
- Check and detect live high voltage cables
- Trace live wires
- Check high frequency radiation
- Check grounding equipment
- Detect residual or induced voltages

### **4. Features & specifications**

- Power ON/OFF function
- Circuit Test function
- Press the Test button to make sure the whole circuit is working well before testing actual high voltage circuits.
- 2 ranges for selection (2 function buttons)

Low : 50V~1.5kV

Press the LOW button, H277 HP is ready for low voltage detection.

HIGH :1.5kV~132kV

Press the HIGH button, H277 HP is ready for high voltage detection.

- Power consumption :

OFF : Less than 5 $\mu$ A

Low voltage detection mode: Less than 40mA

High voltage detection mode : Less than 40mA

- Duty cycle : Continuous
- Response Time : Instantaneous
- Operating temperature : 0~50°C
- Power source : Alkaline battery 9V x 1
- Dimensions : 318(L) x 75(W) x 71(D) mm
- Weight : Approx. 227g (Battery included)
- Accessories :            Instruction manual  
                                  Carry case  
                                  Battery
- Optional Accessory : HS-175 Telescopic hot stick  
                                  HS-120 Hot stick

## 5. Instrument layout

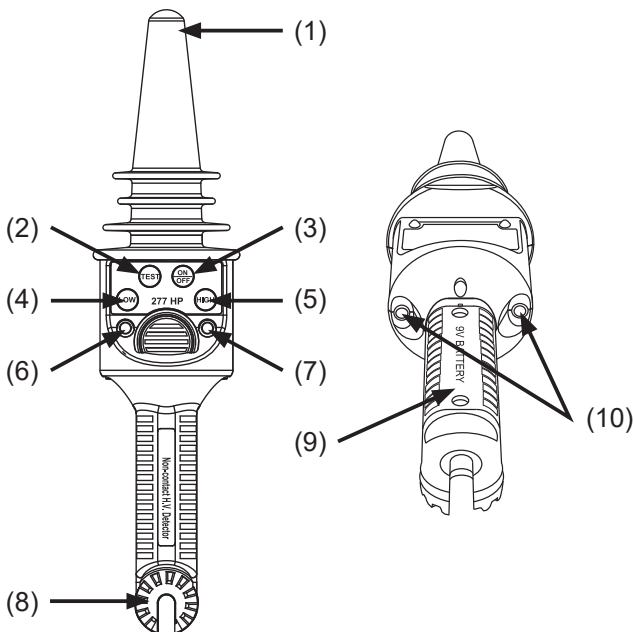

- (1) Voltage sensor (7) HIGH range LED
- (2) TEST button (8) The connection point of
- (3) ON/OFF button Hot Stick
- (4) LOW range button (9) Battery cover
- (5) HIGH range button (10) Blue LEDs for detection
- (6) LOW range LED

## 6. Operation

### ● **ON/OFF button**

When users turn on the H277 HP, the 2 blue LEDs will flash and the buzzer will generate a sound intermittently. The red LED of the HIGH range will be turned on. The original mode is the HIGH range.

### ● **TEST button**

Press the TEST button to do the self-test first, this is to make sure the circuits inside the H277 HP is ok.

When you press the TEST button, the 2 blue LEDs will glow and the buzzer will generate a sound continuously.

The red LED of the HIGH range will be still on (the original mode). If the 2 blue LEDs do not glow and the continuous sound doesn't be generated, please replace with a new battery.

### ● **LOW range button(Low voltage detection)**

Press the ON/OFF button to turn on the high voltage detector.

Press the LOW range button, the 2 blue LEDs will flash and the buzzer will generate a sound intermittently.

The red LED of the LOW range will be turned on.

The LOW range for low voltage detection :50V~1.5kV.

Place the probe sensing tip of the high voltage detector near a low voltage line(50V~1.5kV), but not touching the line.

The blue LEDs will flash very fast and the frequency of the sound will be at the same rate if a voltage is present.



When the probe sensing tip makes contact or is very close to the voltage line, the blue LEDs will glow and the sound will last continuously.

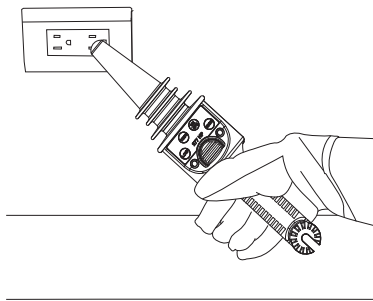

Voltage detection for a wall outlet

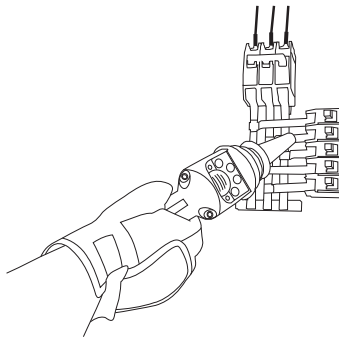

For finding a breaker

● **HIGH range (High voltage detection, HS-175, HS-120 Hot stick must be attached)**

Press the ON/OFF button to turn on the high voltage detector.

The 2 blue LEDs will flash and the buzzer will generate a sound intermittently. The red LED of the HIGH Range will be turned on.

The original mode is the HIGH range for high voltage detection :1.5kV~132kV.

Place the probe sensing tip of the high voltage detector near a high voltage source (1.5kV~132kV), but not touching the high voltage source.

The blue LEDs will flash very fast and the frequency of the sound will be at the same rate if a high voltage is present.

When the probe sensing tip is getting closer to the High voltage source, the blue LEDs will glow and the sound will last continuously.

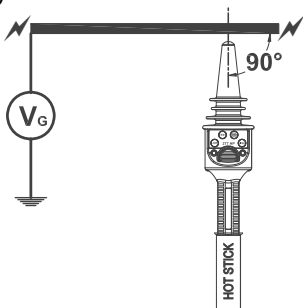

The ideal detection angle

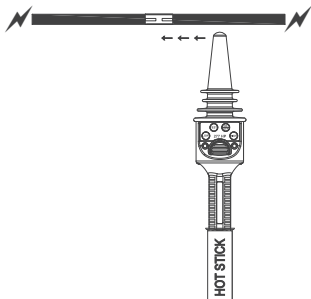

For finding a break of cable

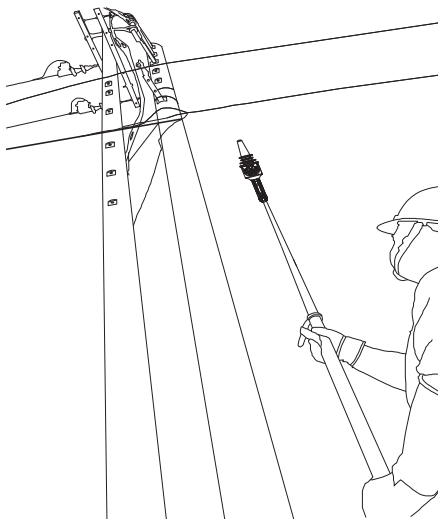

Voltage detection for a line

## 7. Maintenance

### ● Battery replacement

- (1) Unscrew the battery cover on the rear with a screwdriver, then slide the battery cover off the tester.
- (2) Take out the battery.
- (3) Replace with a new battery (9V).
- (4) Reinstall the battery cover and fasten the cover screws.

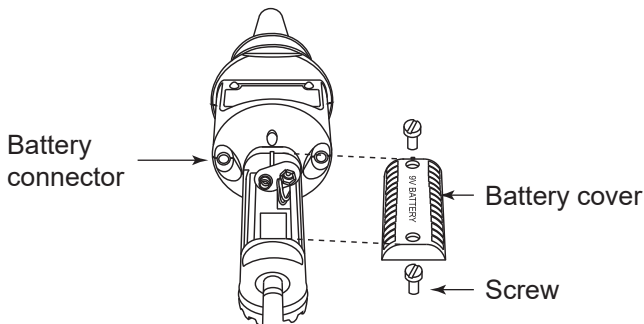

### ● Cleaning and storage



#### **WARNING**

**To avoid electrical shock or damage to the detector, do not get water inside the case.**

- (1) Periodically wipe the case with a damp cloth and detergent; do not use abrasives or solvents.
- (2) If the detector is not used for periods of longer than 60 days, remove the battery and store them separately.