



Hoyt Installation Instruction

D.C. Moving Coil Ammeters And Voltmeters

WIRING

Connect the instrument as shown in the appropriate connection diagram. Terminal studs should be tightened sufficiently to ensure good contact but should not be over-tightened. The magnetic shielding of these instruments makes it unlikely that they could be affected by stray fields, but due precautions should be taken in keeping wires carrying heavy currents as far away from the instrument as is possible.

GROUNDING

On a metal panel which is itself grounded on the instrument's mounting studs will securely ground its case provided care is taken to obtain a good metallic contact through any paint on the rear surfaces of the panel. On non-metallic panels, one of the mounting studs should be connected to the ground.

AMMETERS

Direct-connected ammeters may be used on all loads up to and including 60 amps. For higher currents use an external shunt with a suitably scaled 50mV ammeter indicator.

VOLTMETERS

Voltmeters may be direct-connected up to a maximum of 800 Volts, and must be protected by fuses.

MOVING COIL RECTIFIER INSTRUMENTS

For these A.C. instruments use the connection diagram page.

SHUNTS

A shunt dissipates the heat generated by the passage of current more by conduction and convection than by radiation. It is therefore necessary that the ends of shunts and of the conductors connected to them are of such cross-section and of such contact area as to prevent any undue temperature rise. Where the shunt is built up of a number of strips of metal, cooling is best effected when the shunt is mounted horizontally with the strips in a vertical plane. If the shunt has to be mounted vertically with one terminal above the other, then the positive terminal should be the lower since, owing to the Peltier effect, the terminal at which the current enters the shunt will normally develop more heat than the other terminal.

SHUNT LEADS

A standard length of 5 ft. with resistance of 0.065 +/- 0.01 ohm should be used. They must not be cut and any excess length should be coiled and taped up close to the rear of the instrument. If the purchaser supplies shunt leads their resistance must agree with that quoted for the standard leads. Leads longer than 5 ft. can be supplied to order. If particularly long leads are unavoidable it may be necessary to use shunts and indicators of 100 mV ratings; the maximum lead resistance is approximately 0.25 ohm for 50 mV ratings and 1 ohm for 100mV ratings.

A.C. Ammeters And Voltmeters

WIRING

Connect the instrument as shown in the appropriate connection diagram. Terminal studs should be tightened sufficiently to ensure good contact but should not be overtightened. The efficient magnetic shielding of these instruments makes it unlikely that they could be affected by stray fields, but due precautions should be taken in keeping wires carrying heavy currents as far away from the instruments as is possible.

GROUNDING

On a metal panel which is itself grounded to the instrument's mounting studs will securely ground its case provided care is taken to obtain a good metallic contact through any paint on the rear surface of the panel. On non-metallic panels one of the mounting studs should be connected to ground. If current or potential transformers are used, the grounded side of the secondary should be connected to one of the instrument's grounded studs.

AMMETERS

For motorized circuits the use of an overload scale ammeter, either self-contained or C.T. operated, is strongly recommended. Its 6times overload scale enables the instrument to withstand without damage frequent applications of high starting currents. Current transformers with a suitably scaled ammeter indicator must be used on all loads in excess of 30 amps and on all circuits over 800 volts. **WARNING.** If the secondary circuit of an energized current transformer is open-circuited, dangerously high voltages will be induced in its secondary winding. Any selector switches used in the secondary circuits must be of a type which guards against open-circuiting.

VOLTMETERS

Potential transformers with a suitable scaled voltmeter indicator must be used on all circuits over 800 volts. All voltmeters or their associated P.T.'s must be protected by fuses.



Hoyt Installation Instruction

Mounting

Cut and drill panel as indicated in Fig.1. All drilling and wiring on the switchboard should be completed before mounting the instrument, and it is desirable to defer mounting as long as possible to reduce the risk of accidental damage to the front cover of the instrument while work is proceeding on the switchboard.
After mounting, correct any pointer deviation from zero by means of the zero adjuster.

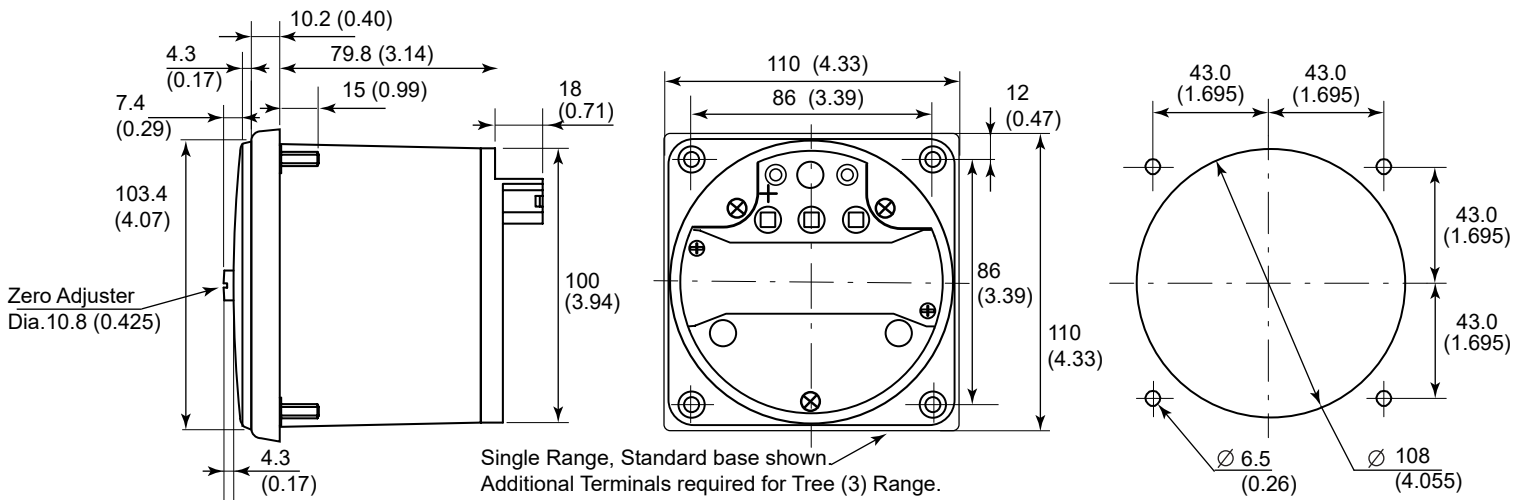

Fig. 1. HLS-110 Panel drilling plan. For instrument Dimensions.

General

CLEANING

Before wiping or cleaning the outer surface of the front cover, all dust should be carefully removed brushed off to avoid any scratches on its surface. Any superficial scratching which the plastic windows may sustain can be removed by careful use of an acrylic-polishing agent. Care should be taken to avoid contacting plastic windows with spirit-based liquids, as this would cause severe crazing.

COVER REMOVAL

Extreme precautions are taken in the factory to prevent the ingress of any dust into the interior of the instrument. Similar steps must be taken should it be necessary to remove the front cover of the instrument for any reason. The following procedure should be observed:

1. On no account should the cover be removed in circumstances where any particles or dirt could conceivably enter the interior.
2. Every precaution should be taken to avoid the entry of dust. The operation should be carried out in reasonably dust free conditions, and free from draughts or crosscurrents of air.
3. When the cover is removed it should immediately be placed, inner surface downwards, on a clean sheet of paper, so that no dust should settle on its inner surface. Care should be taken not to rub or even touch the inner surface so far as to avoid damage to the anti-static treatment applied at the factory.
4. Should it be necessary to leave the cover off the instrument for any length of time, the instrument should be screened from dust by being placed in a clean dust-free bag or container, preferably transparent. Care should be taken in doing this avoid damaging the exposed pointer, dial, etc.
5. The cover must be replaced carefully, to ensure that the pin on the zero adjuster engages properly with its slot in the zero adjuster arm on the top of the cross-bar of the instrument mechanism.

REPAIRS

It is unlikely that the instruments will ever need servicing or repair. Should any instrument suffer mechanical or electrical abuse as to affect its operation, it should be returned to the manufacturer for attention.

The assembly and adjustment of the mechanism can be carried out only by trained factory personnel.

HOYT HLS-110 & HLS-80 WIRING DIAGRAMS

HLS-80 & HLS-110 - AC/DC Volts
HLS-80Hz - HLS-110Hz

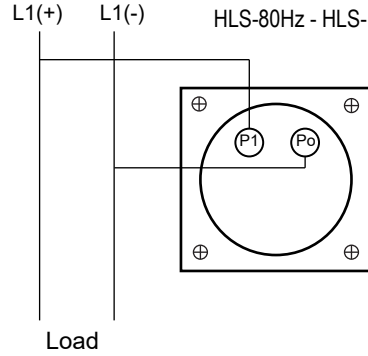

HLS-80 & HLS-110 - AC/DC Amps

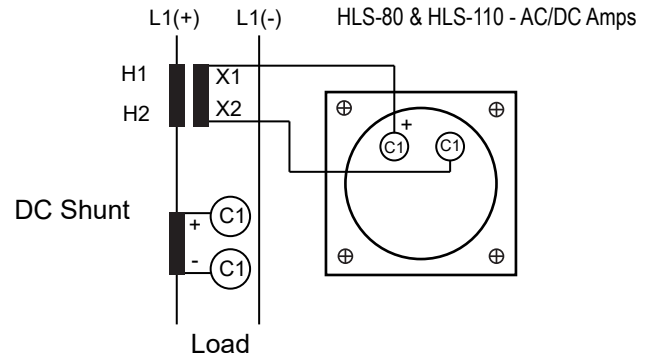

HLS-80KW12, HLS-110KW12
HLS-80KVAR12, HLS-110KVAR12
HLS-80PF12, HLS-110PF12

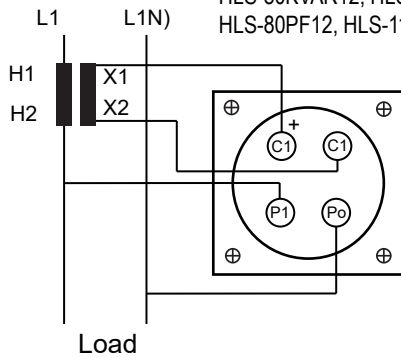

HLS-80PF33/4, HLS-110PF33/4

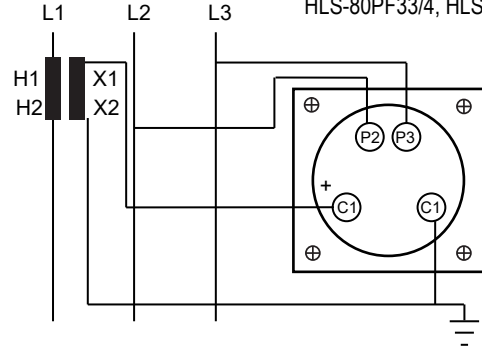

HLS-80KW33, HLS-110KW33
HLS-80KVAR33, HLS-110KVAR33

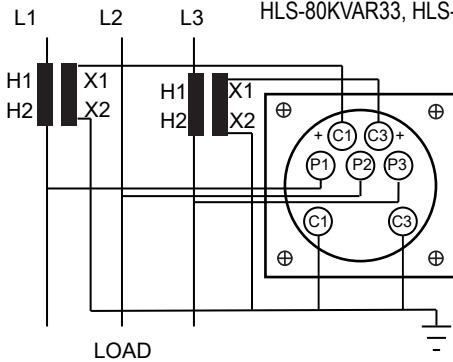

HLS-80KW34, HLS-110KW34

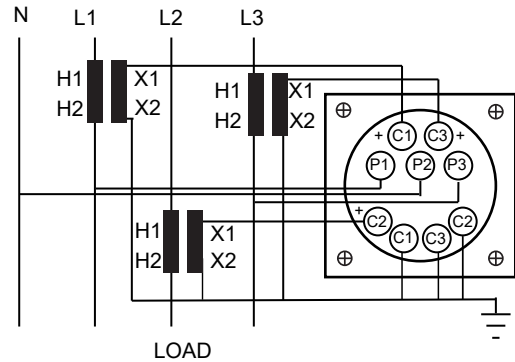

HLS-80KVAR34, HLS-110KVAR34

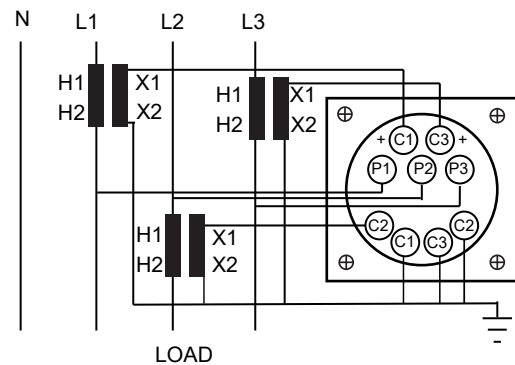

Legend

P1,2,3 = Voltage Connections

C1,2,3 = Current Transformer

Be sure X1 and X2 on Ct is mounted correctly on meter